

Mercedes-Benz Arocs 1836 4x4 with personell and cargo body.

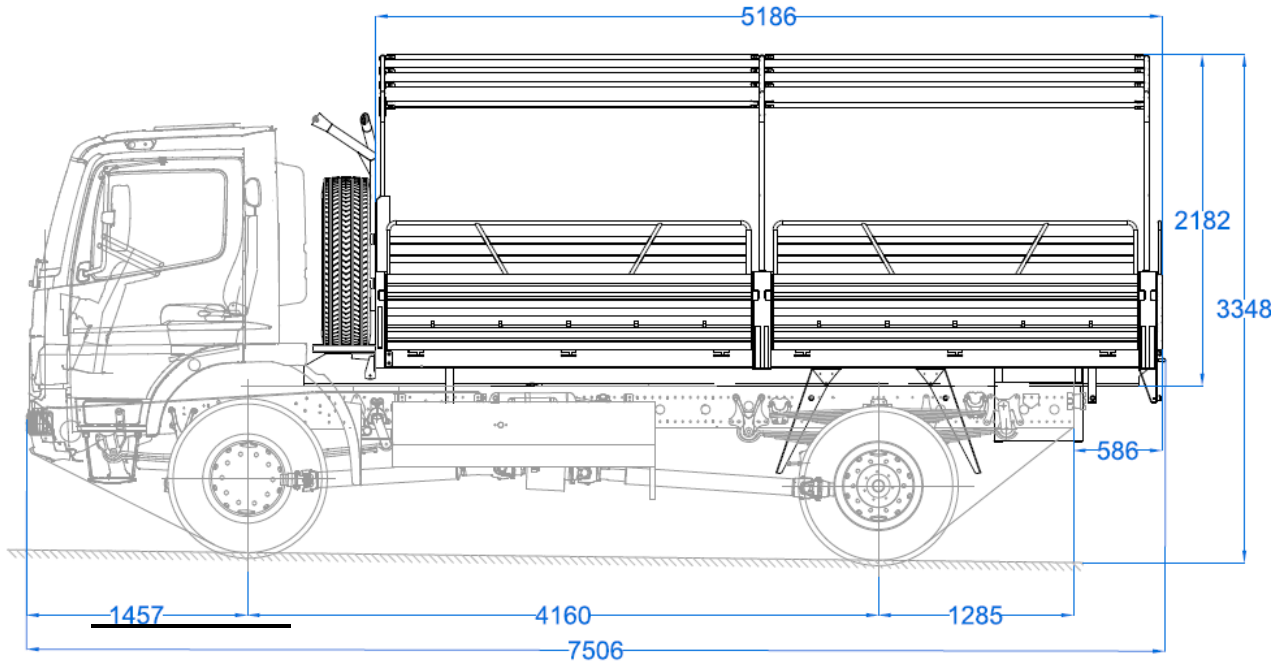

- Chassis: Mercedes-Benz Atego 1836 4x4
- Wheelbase: 4160 mm

2. Operations

- ELS Personnel transport and cargo body are designed for transport (Troops and Cargo).
- Designed to perform in rough road conditions.

3. Cargo Body Characteristics

- Low Torsion execution.
- Body structure manufactured in high quality Steel, S235JR.
- Suitable to transport people and/or load.

APPROX. DIMENSIONS:

- External Length: 5200 mm
- External Width: 2550 mm
- Internal height: 1900 mm
- Height of front wall: 1000 mm
- Height of side walls 500 + 350 mm (backrest)
- Height of rear wall: 500 + 350 mm (steps)

Floor:

- Floor made of checkered (ANTI-SLIP) steel 3/5 mm, S235JR.
- Anchoring rings embedded on floor to ensure load (10 units, 5 on each lateral)
- Steel Mudguards for each wheel (rear axles) integrated in the platform with anti-stone chipping treatment applied.

Drop Sides:

- Lateral drop sides and rear tailgate are foldable and removable (no tools needed to remove them) so the body can be used like Flat rack configuration.
- Drop sides walls are also interchangeable among them.
- Front side fixed.
- One removable stanchion on each rear corner and two centers stanchion on each lateral side converts the side walls into **2** equal parts. Stanchions have side locks.
- Rear handles at rear
- Foldable steps for access mounted on rear tailgate
- Rubber pads to stop drop sides walls when are folded in order to avoid damages.



*Pictures are an example of previous product, actual product will be delivered with two separate sides instead of shown three sides.



*Pictures are an example of previous product, actual product will be delivered with two separate sides instead of shown three sides.

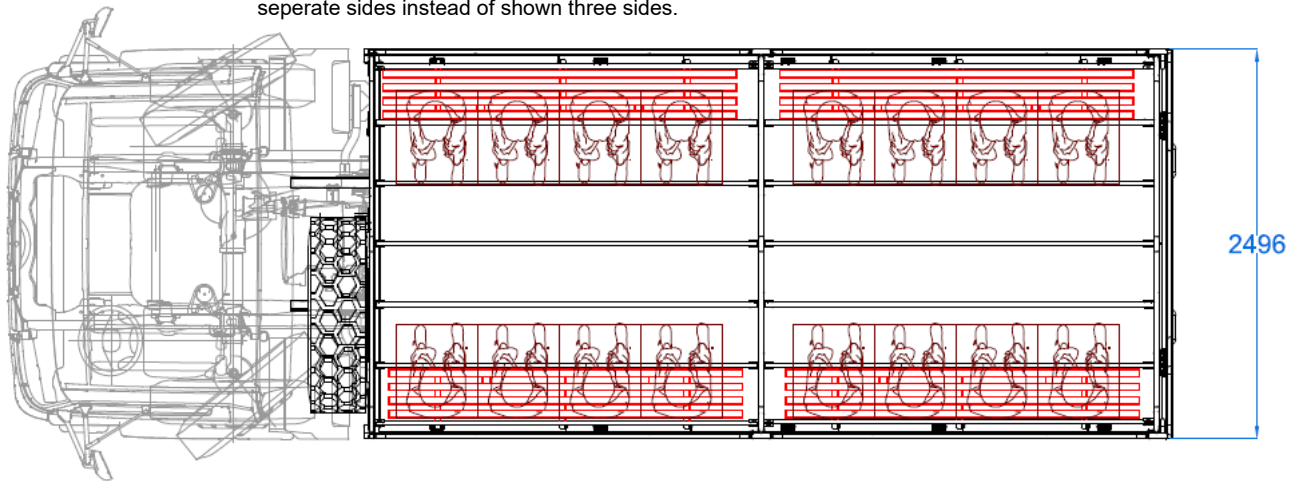

- Seat-benches are fixed on each dropside
- Made of steel, with supports legs when are in sitting position
- Total capacity of seats up to 18 people
- Space for each passenger: 500 mm
- Seats are foldable.
- When transporting general cargo, the seat benches are turned upward with manual action without tools and are ensured with belts.

ROOF, TARPAULIN BOWS:

- Steel arches structures with a tarpaulin are installed to cover the passenger and goods. Robust and strong structure suitable for off-road use.
- The arches are easily removable without tools needed. Locked with unlosable pins.

Tarpaulin:

- Made of PVC, 630g/m², with UV protection (made in Spain, EU) (DIN 4102 B2)
- Waterproof cover, openable and rollable on the lateral sides and rear.
- Reinforced on the most critical parts for off-road use.
- Colour: White RAL colour



*Pictures are an example of previous product, actual product will be delivered with two separate sides instead of shown three sides.

4. Accessories included:

- Toolbox fixed on the chassis (lockable)
- Lockable military jerry can holder fitted for 2 jerry cans: one for water and one for fuel.
- Spare Wheel Holder, mounted between cabin and body. Operated with manual winch to load/unload the wheel.

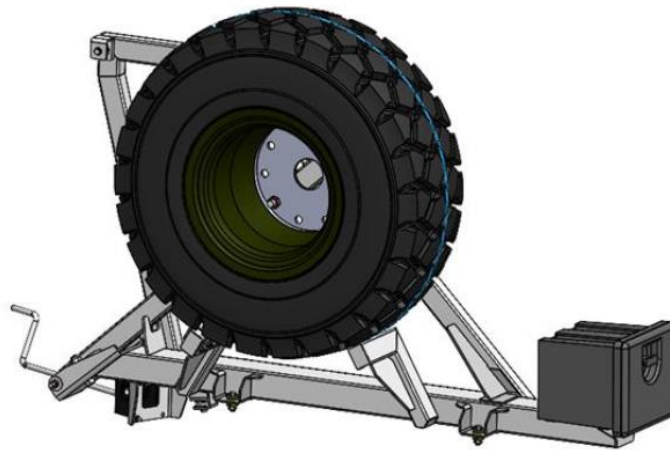

5. Painting:

During the metalwork process all the overlapped points are covered with an epoxy primer. All the steel elements will receive a sandblasting treatment (SA 2 ½ acc.to SIS standard) before painting. Joints prepared and sealed to prevent corrosion.

No IR paint

Wax protection included.

White RAL COLOUR